



FocusCNC®

FBL-300/L/MC

FBL-360/L/MC

FBL-460/L/MC

Box Way Series **CNC Lathes**



Box Way Series

CNC Lathes

FBL-300/L/MC

FBL-360/L/MC

FBL-460/L/MC

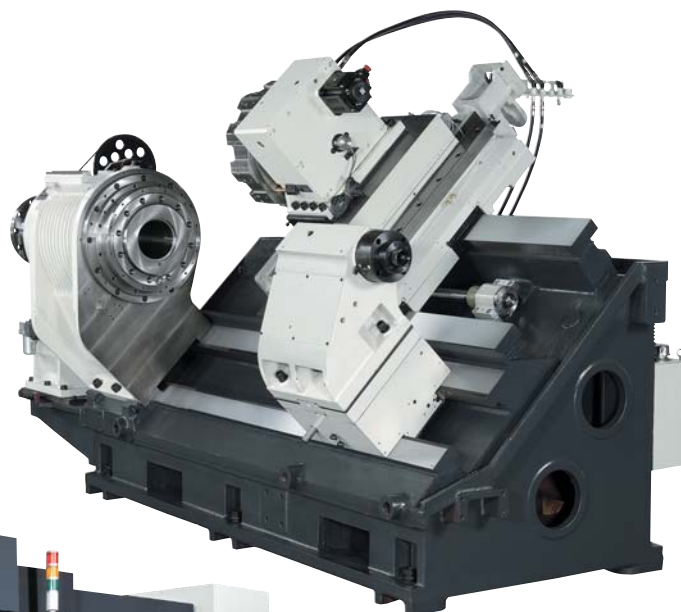

Contents

02

Controller

03

FBL-300/360/460/L/MC Series
Construction & Spindle
Transmission System

04

FBL-300/L
System Diagram

05

FBL-300/360/L/MC
System Diagram

08

FBL-460
System Diagram



Controller

FANUC

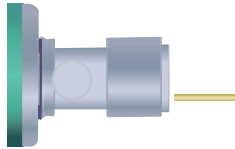
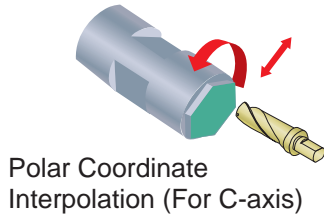
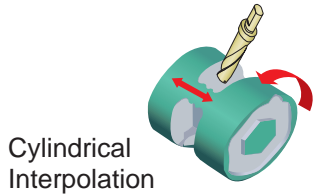

Manual Guide i (opt.)
Conversational editing with 3D simulation available.

SIEMENS



Uses a 10.4" screen for easy operation. Optional Shop Turn function with integrated operating system. Finish programming without having to use G-code.

- 2 window view dynamic simulation
- 3D finished part simulation (opt.)
- 3D section view (opt.)

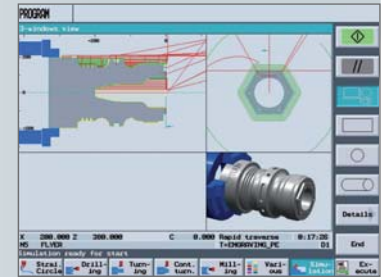

09

FBL-460/L/MC
System Diagram

11

Spindle Torque Diagram

12

Standard & Optional
Accessories

13

Specifications

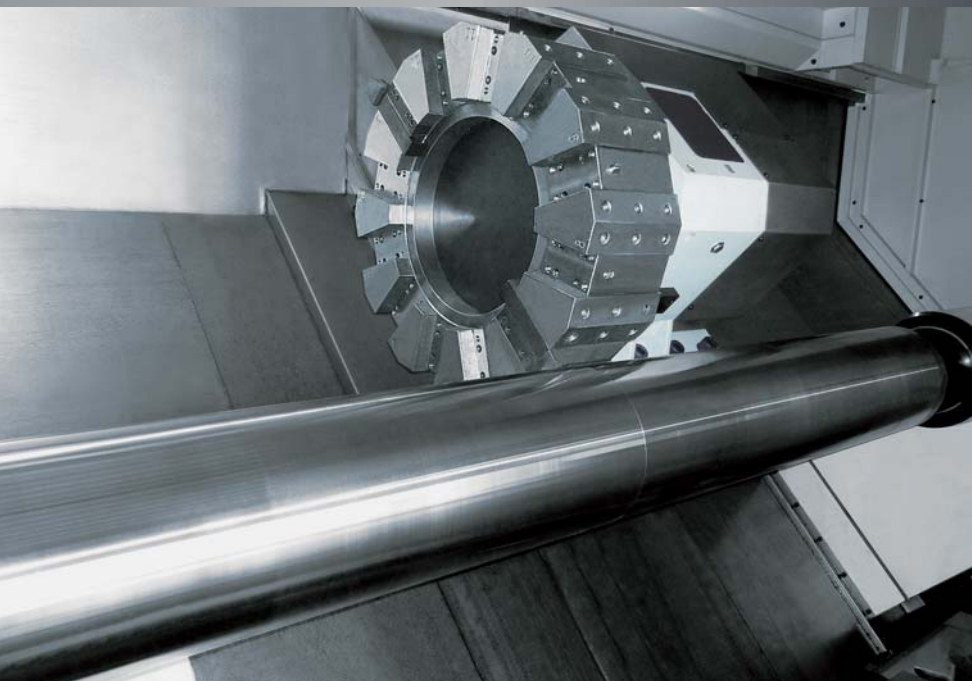

Features

- Sturdy box way model capable of low speed heavy-duty machining.
- Armed with the latest Fanuc Oi control, high resolution LCD screen, and multi-functional interface, for the best possible operating environment.
- High rigidity box way with scrapped slide way and precision oil network design for superb transmission efficiency.
- 45-degree slant bed structure with a low center of gravity, for enhanced machining accuracy.

FBL-300/L/MC Series FBL-360/L/MC Series FBL-460/L/MC Series

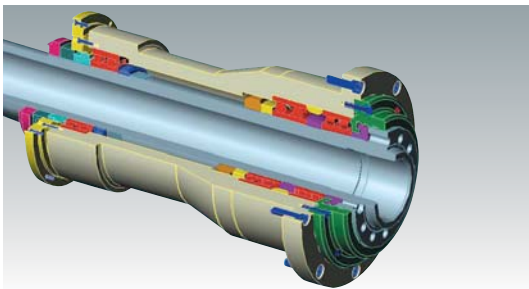

High Precision Spindle System

Module designed spindle and collet type bearings provide greater accuracy and a longer service life than the stock type spindle structure.



Programmable Tailstock System

- Highly rigid machine body results in shock-dampening properties.
- Programmable Z-axis saddle control for automatic tailstock movement. (FBL-300 Option)
- Optional rotating arbor for greater workloads.

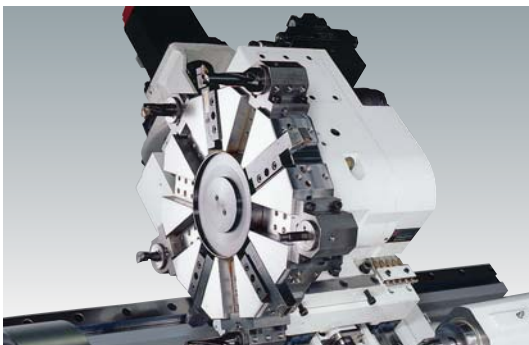

Powerful Turret

- Fitted with a powerful hydraulic turret for heavy-duty machining. Designed with a very rigid structure to meet the strict requirements of high efficiency machining.
- 12 position turret optional.



High Torque Spindle Transmission System

- Two-stage star gearbox featuring full throttle high torque output, or low speed for high torque turning properties.
- (FBL-360/460/L)
- Imported high intensive pitch type belt provides a firm grip without slipping. Outfitted with a low noise transmission device with good heat transmission, for excellent heat radiation. Also features easy maintenance and adjustment.

FBL-300/L System Diagram

Unit: mm

FBL-300 Tooling System

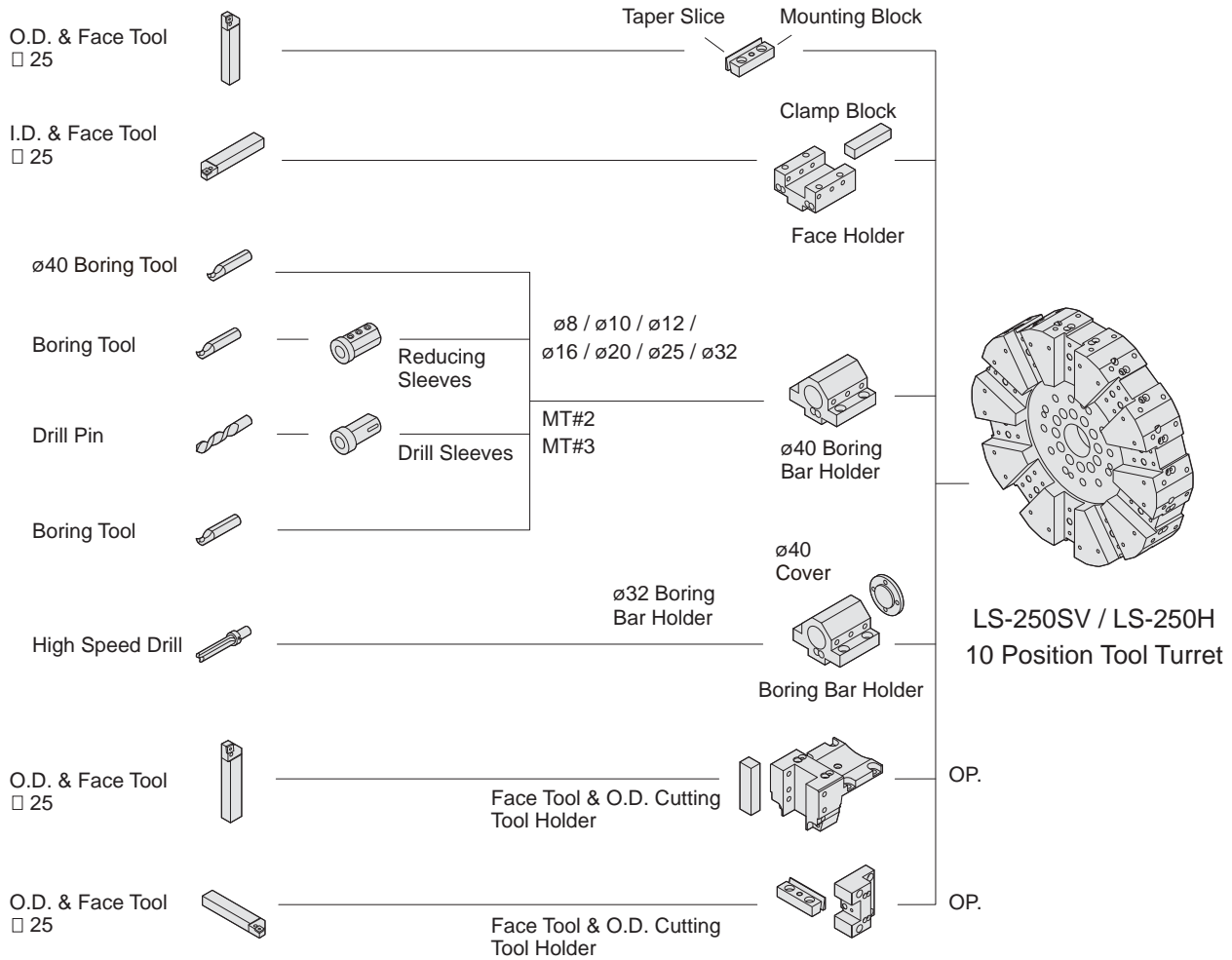

FBL-300 Tool Interference

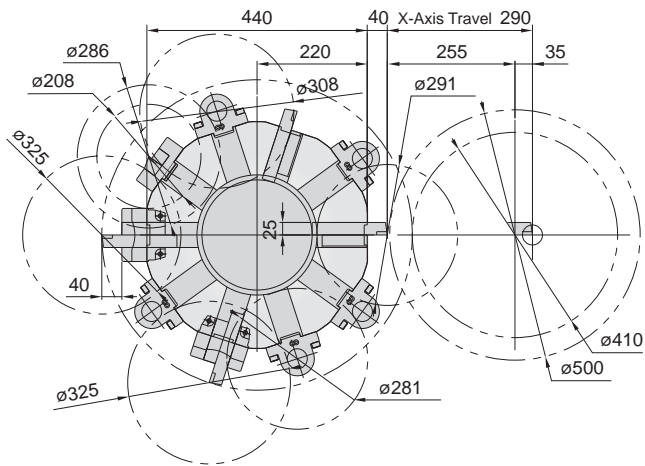

Standard 10 Tools+10" Chuck

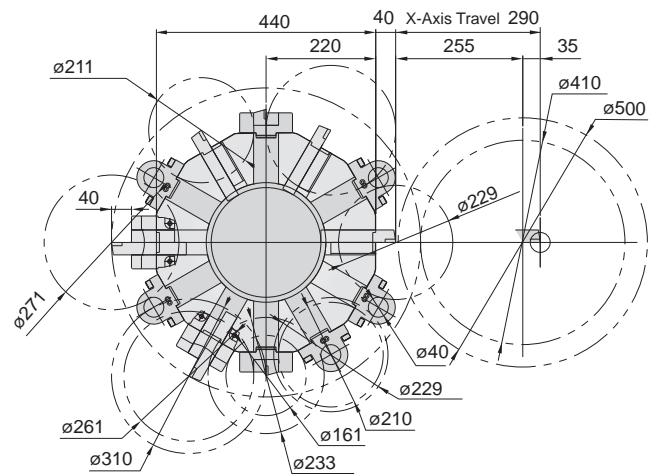

Optional 12 Tools

FBL-300/360/L/MC System Diagram

Unit: mm

FBL-300 Spindle Structure

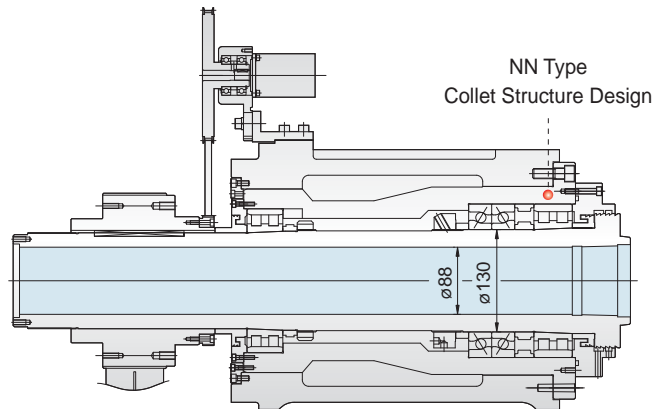

FBL-300 Machining Area

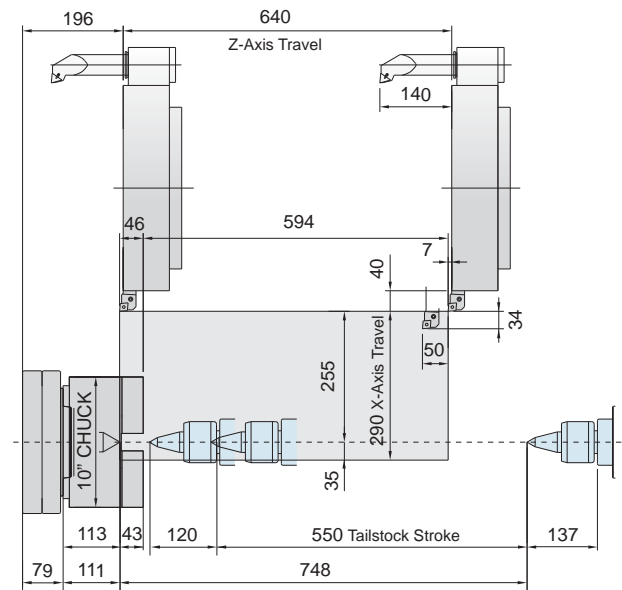

FBL-300MC Tooling System BMT 65

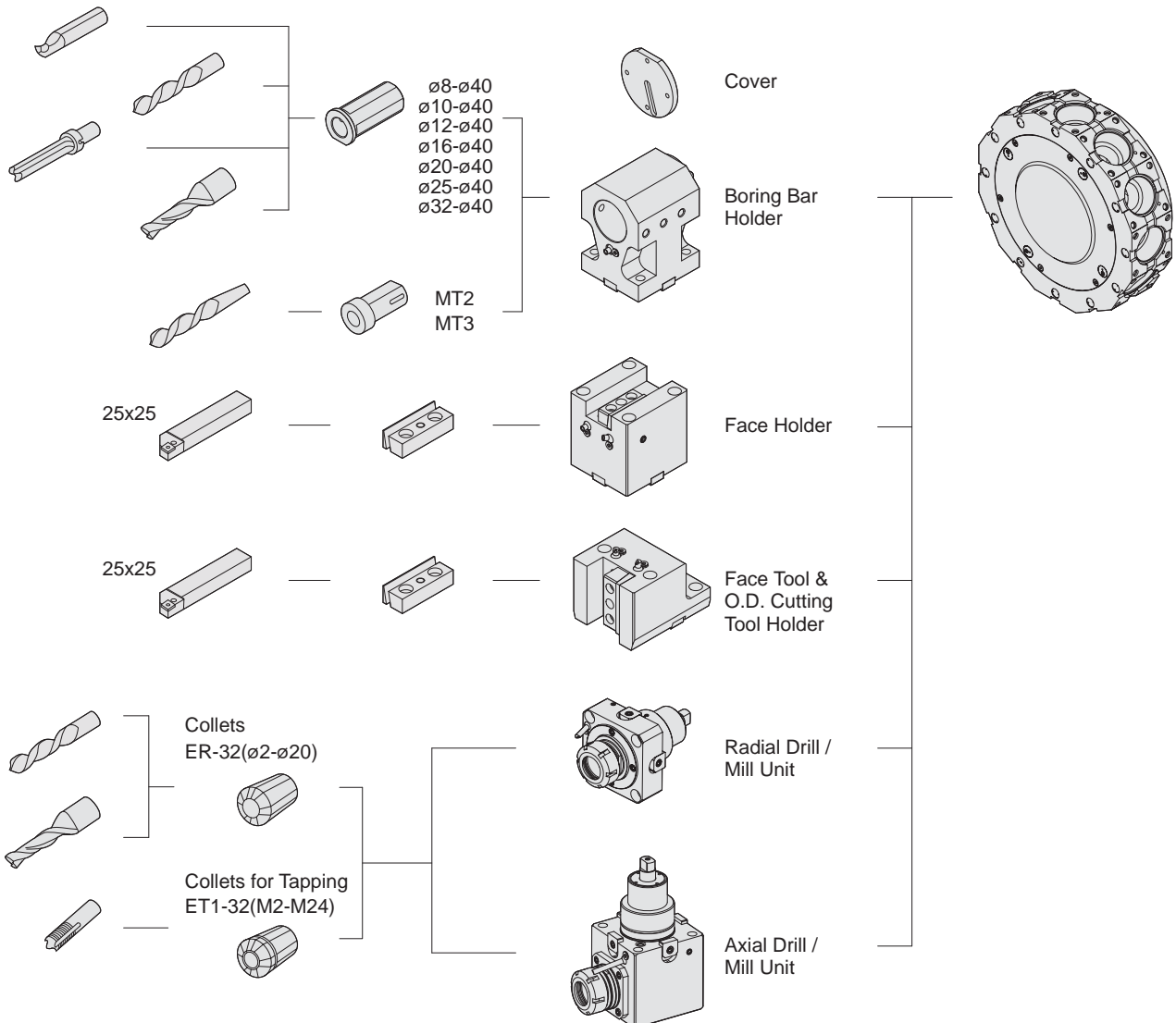

FBL-300MC Tool Interference BMT 65

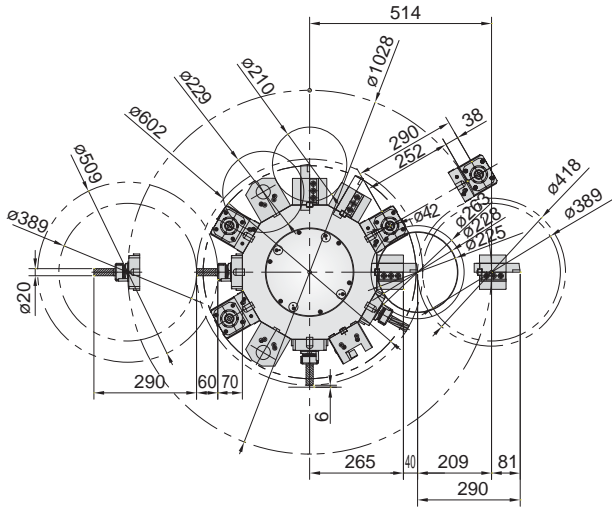

FBL-300MC Machining Area BMT 65

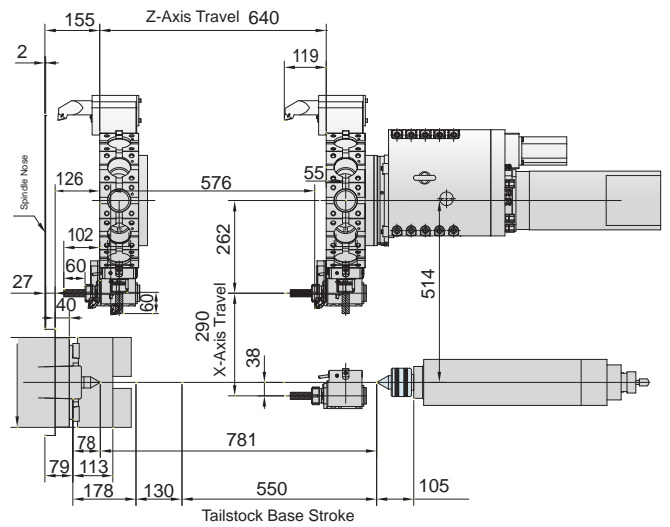

FBL-360 Tooling System

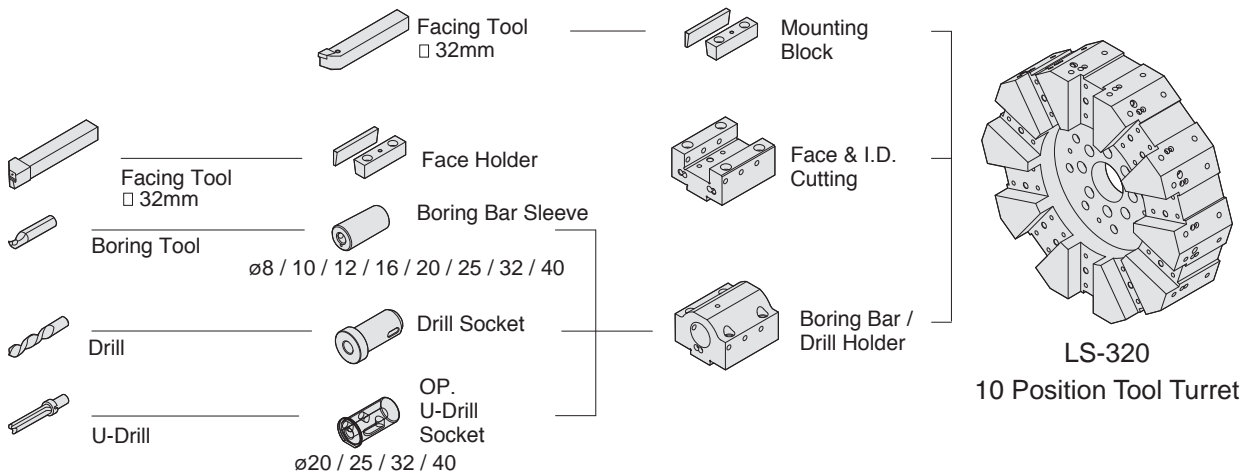

FBL-360 Tool Interference

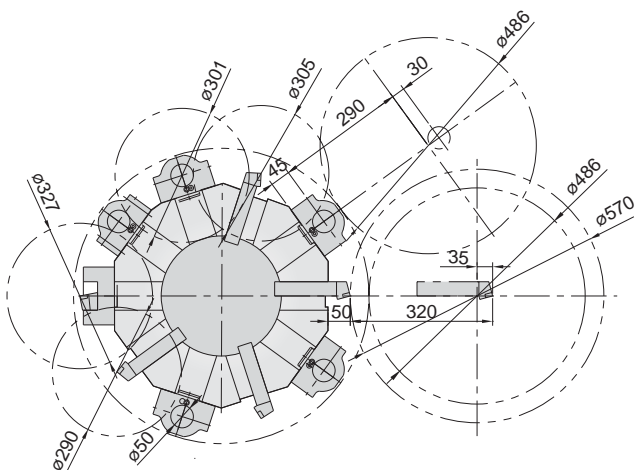

FBL-360 Spindle Structure

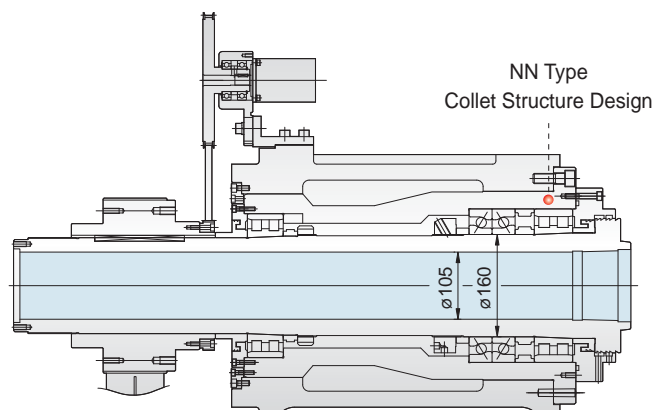

FBL-300/360/460/L/MC System Diagram

Unit: mm

FBL-360 Machining Area

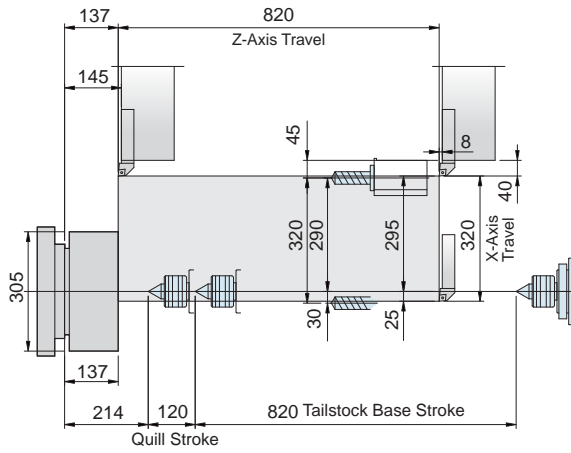

FBL-360L Machining Area

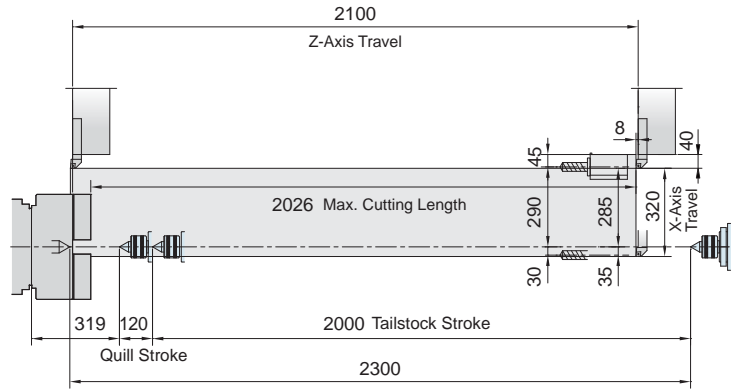

FBL-360MC Tooling System BMT 75

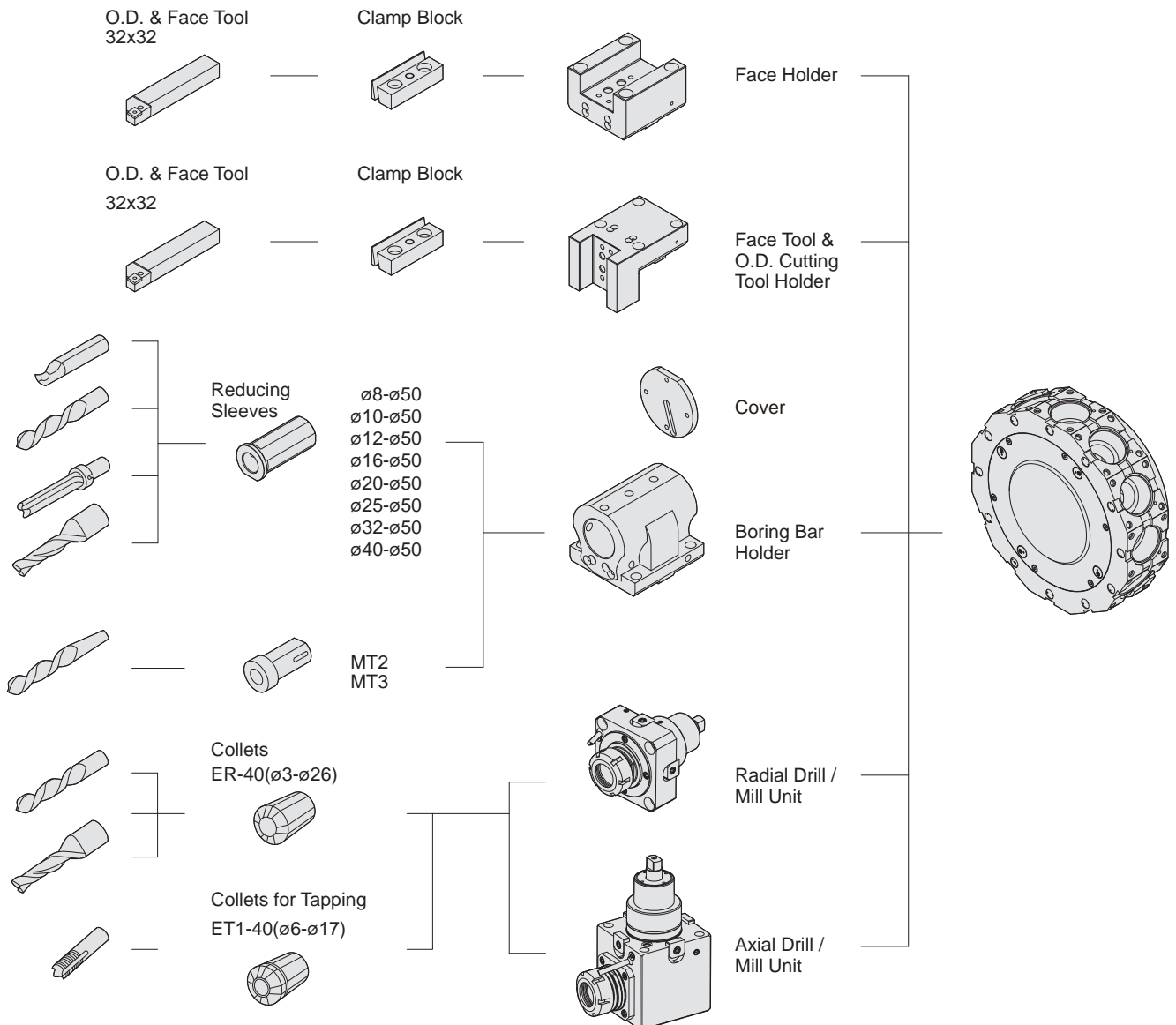

FBL-360MC Tool Interference BMT 75

FBL-360MC Machining Area BMT 75

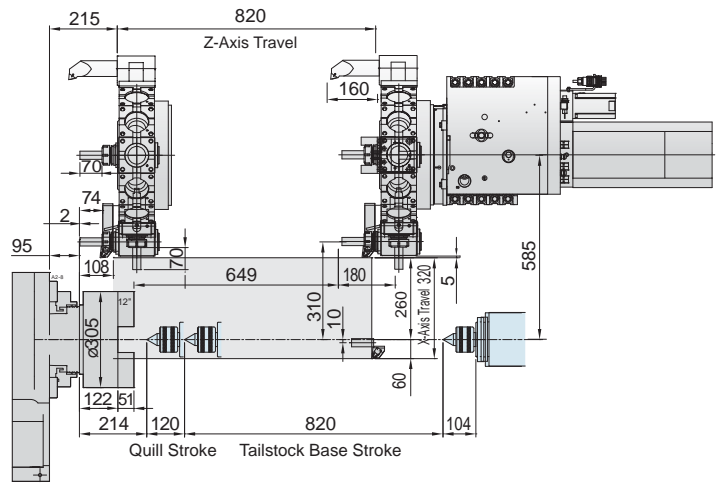
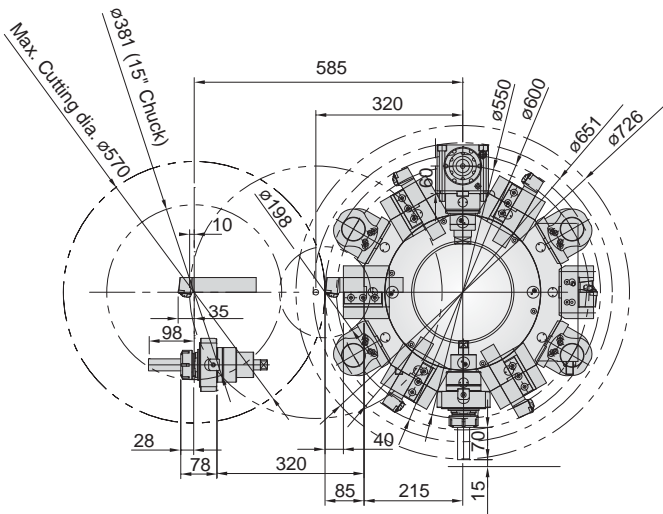

FBL-460 Tooling System

For Direct Mounting on Turret

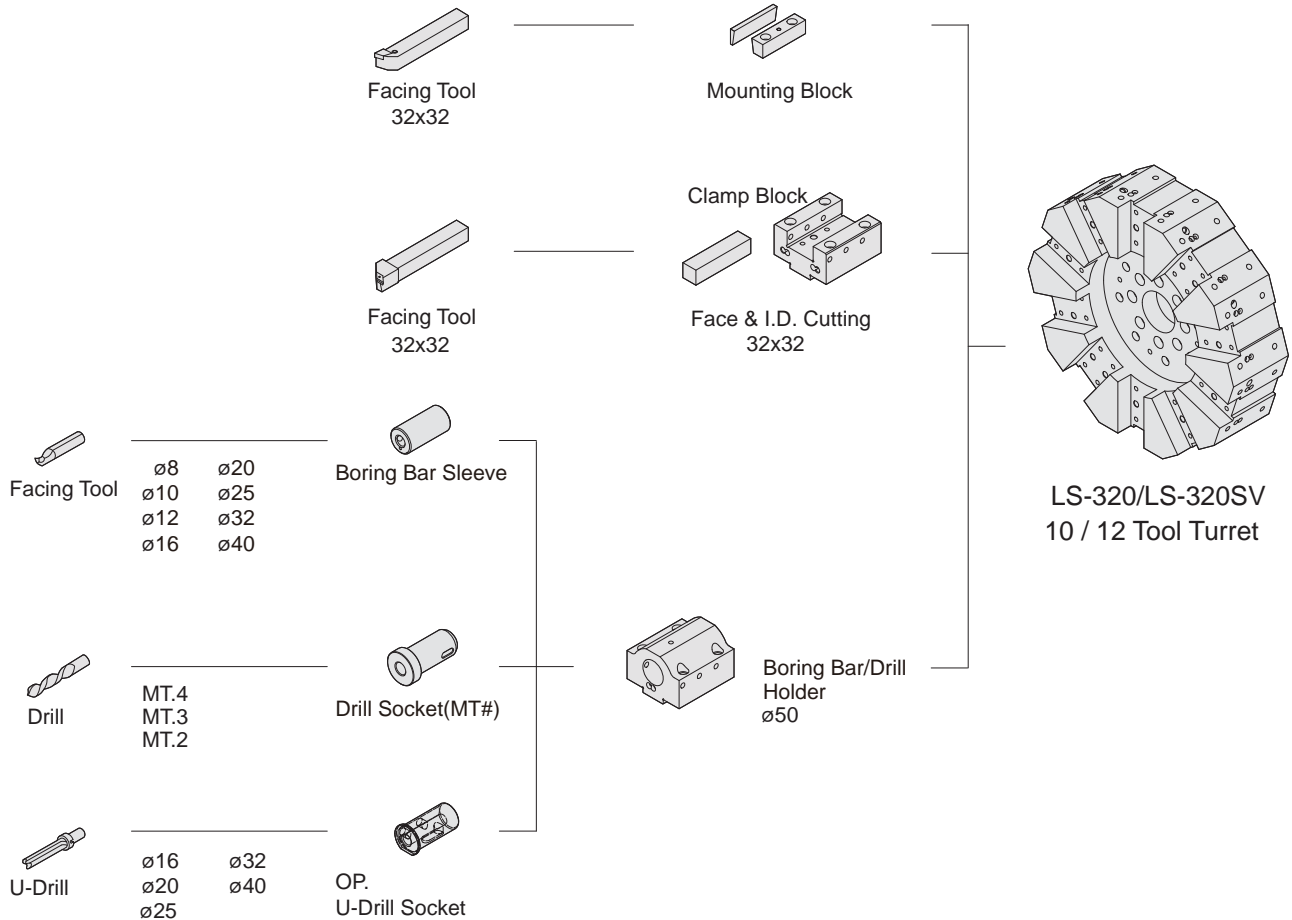

FBL-460/L/MC System Diagram

Unit: mm

FBL-460 Tool Interference-10T

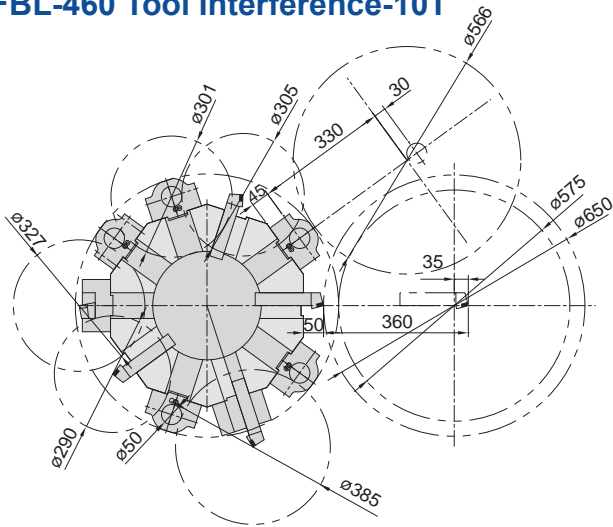

FBL-460 Tool Interference-12T

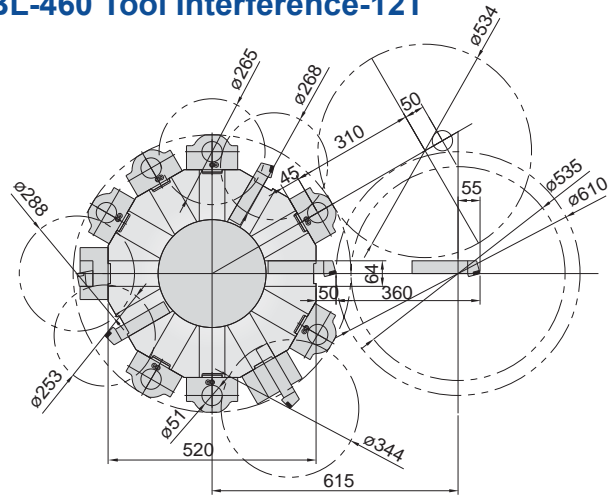

FBL-460MC Tooling System BMT 75

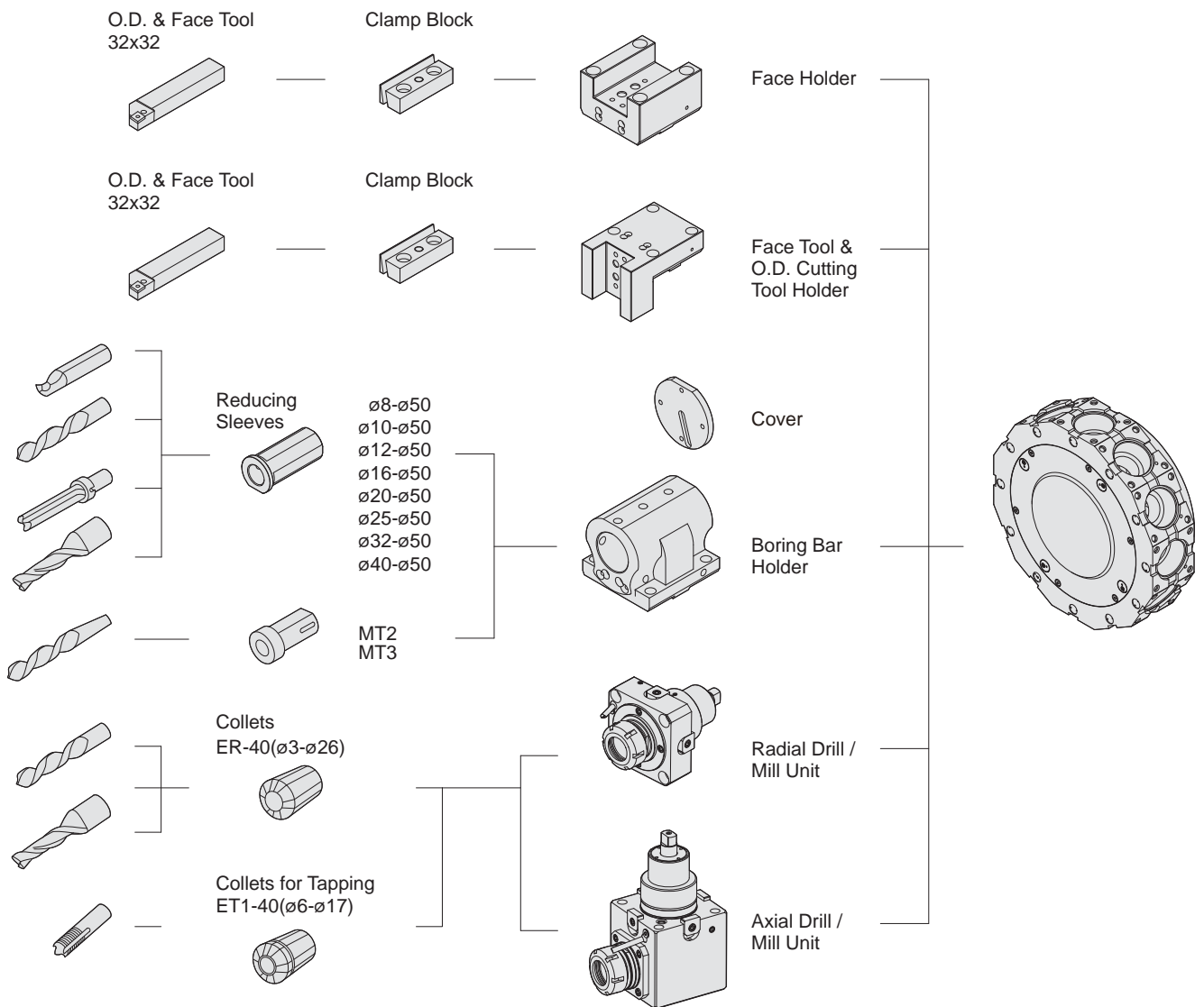

FBL-460 Machining Area

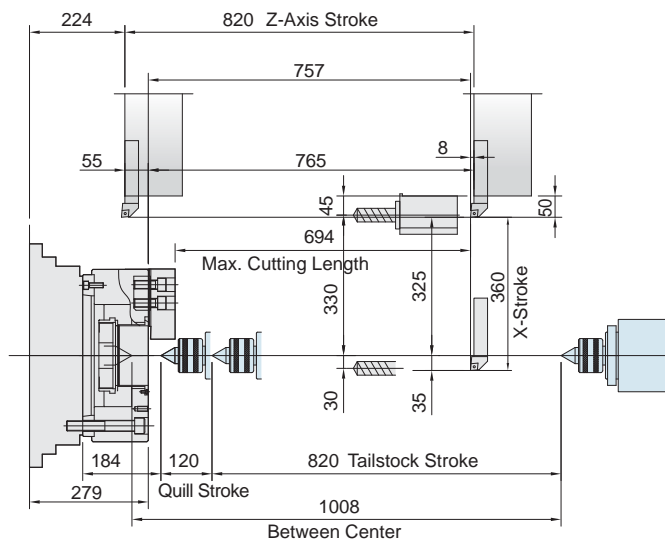

FBL-460 Spindle Structure

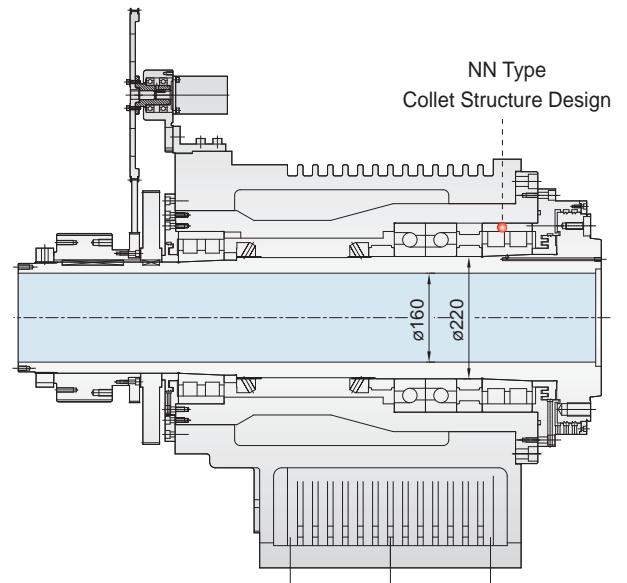

FBL-460L Machining Area

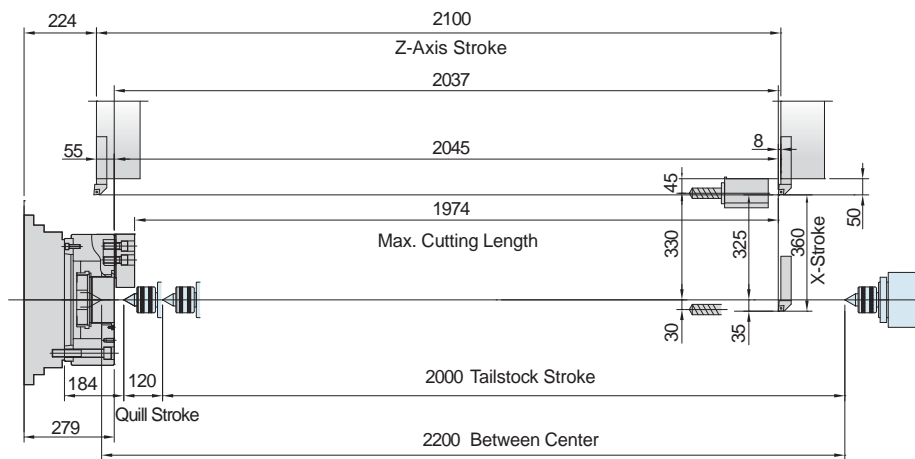

FBL-460LMC Machining Area

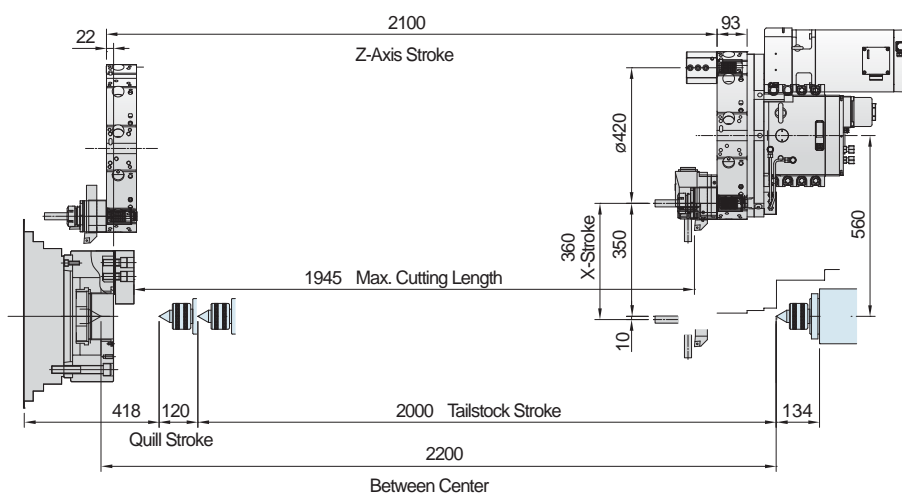

Spindle Torque Diagram

Unit: mm

FBL-460MC Tool Interference BMT 75

FBL-460MC Machining Area BMT 75

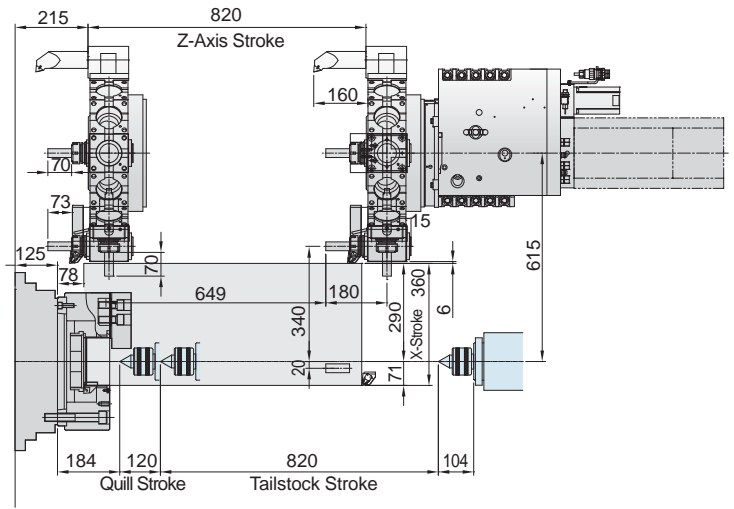
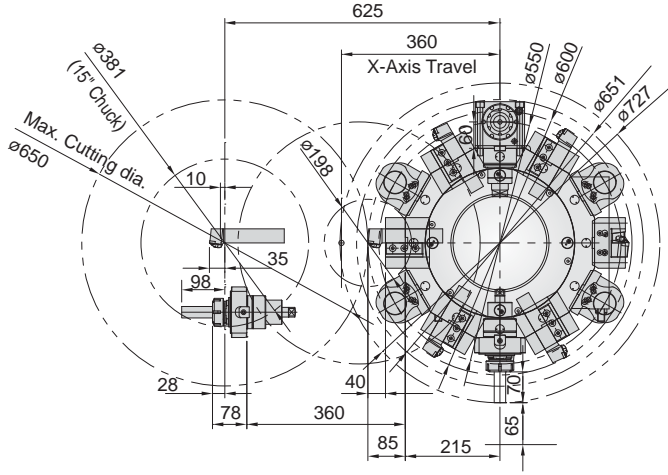

FBL-300/L/MC Spindle Torque

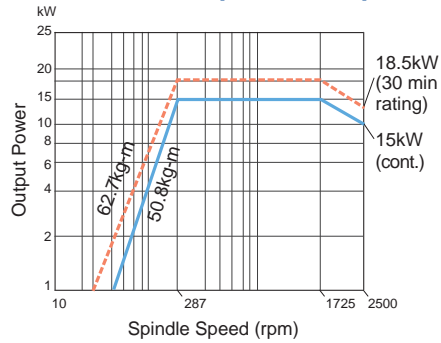

FBL-300MC Power Tool Torque

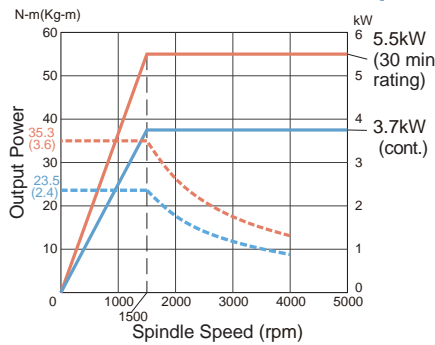

FBL-360 FANUC α22i+ Gear Box

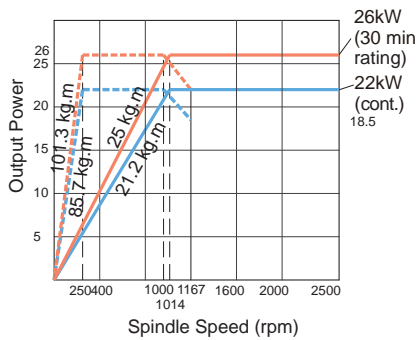

FBL-360MC FANUC αP40i

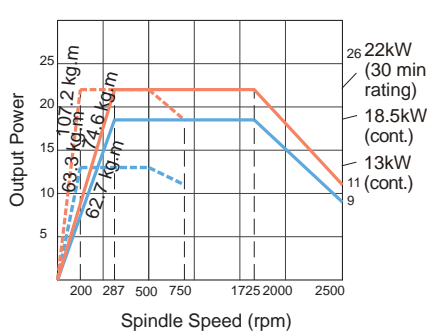

FBL-360MC/460MC Power Tool Torque

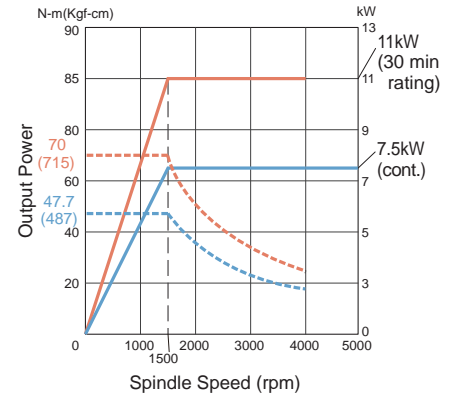

FBL-460 FANUC α22i+ Gear Box

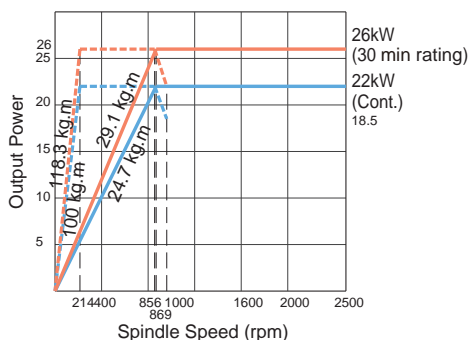

FBL-460 FANUC α30i+ Gear Box

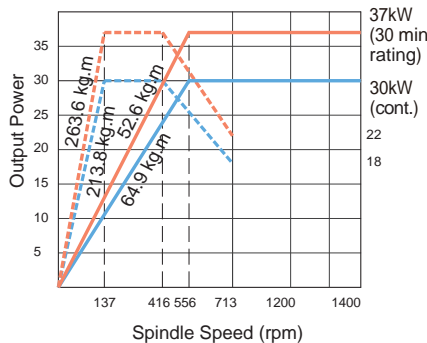

Standard & Optional Accessories

● Standard △ Optional

MODEL	FBL-300	FBL-300MC	FBL-300L	FBL-360	FBL-360MC	FBL-360L	FBL-460	FBL-460MC	FBL-460L
10" Hydraulic chuck	●	●	●	-	-	-	-	-	-
12" Hydraulic chuck	-	-	-	●	●	●	-	-	-
15" Hydraulic chuck	-	-	-	-	-	-	●	●	●
Hard jaws (set)	10"x1	10"x1	10"x1	12"x1	12"x1	12"x1	15"x1	12"x1	12"x1
Soft jaws (set)	10"x1	10"x1	10"x1	12"x1	12"x1	12"x1	15"x1	12"x1	12"x1
Hydraulic turret	●	-	●	●	-	●	●	-	●
Servo turret	△	●	△	△	●	△	△	●	△
Boring bar holder	5	△	5	5	△	5	5	△	5
Face holder	2	△	2	2	△	2	2	△	2
Tool sleeve (set)	1	△	1	1	△	1	1	△	1
O.D. tool holder	-	△	-	-	△	-	-	△	-
Coolant system	●	●	●	●	●	●	●	●	●
Movable coolant tank	●	●	●	●	●	●	●	●	●
1 set leveling bolts and pads	●	●	●	●	●	●	●	●	●
Grease lubrication system	-	-	-	-	-	-	-	-	-
Centralized lubrication system	●	●	●	●	●	●	●	●	●
Work lamp	●	●	●	●	●	●	●	●	●
Foot pedal for hydraulic chuck	●	●	●	●	●	●	●	●	●
Tool kit	●	●	●	●	●	●	●	●	●
Manual	●	●	●	●	●	●	●	●	●
Chip conveyor and bucket	●	●	●	●	●	●	●	●	●
MT5 live center	●	●	●	●	●	●	●	●	●
Programmable tailstock	△	△	△	●	●	●	●	●	●
3 color warning light	△	△	△	●	●	●	●	●	●
High pressure cooler	●	●	●	●	●	●	●	●	●
2 step gear box	△	-	△	●	-	●	●	-	●
Parts catcher	-	-	-	-	-	-	-	-	-
Manual tool setting probe	△	△	△	△	△	△	△	△	△
Auto tool setting probe	△	△	△	△	△	△	△	△	△
Oil skimmer	△	△	△	△	△	△	△	△	△
Oil mist collector	△	△	△	△	△	△	△	△	△
Transformer	△	△	△	△	△	△	△	△	△
CE safety accessories	△	△	△	△	△	△	△	△	△
Automatic door (pneumatically driven)	△	△	△	△	△	△	△	△	△
Pedal switch for tailstock	△	△	△	△	△	△	△	△	△
Bar feeder and interface	-	-	-	-	-	-	-	-	-
Collet chuck	-	-	-	-	-	-	-	-	-
Work blower	△	△	△	△	△	△	△	△	△

Specifications

MODEL		FBL-300	FBL-300MC	FBL-300L	FBL-300LMC	FBL-360
Swing over bed	mm	654	654	654	654	770
Swing over cover	mm	418	418	418	418	550
Max. cutting diameter	mm	510	390	510	390	570
Max. cutting length	mm	594	554	1554	1514	762
Distance between centers	mm	748	748	1708	1708	1020
Spindle nose	ASA	A2-8	A2-8	A2-8	A2-8	A2-8 (A2-11)
Chuck size	inch	10 (12)	10 (12)	10 (12)	10 (12)	12 (15)
Spindle hole diameter	mm	88	88	88	88	105 (134)
Spindle speed	rpm	2500	2500	2500	2500	2500 (1500)
Spindle motor (cont/30min)	kW	15 / 18.5	15 / 18.5	15 / 18.5	15 / 18.5	22 / 26 (30 / 37)
Max. bar material diameter	mm	77	77	77	77	91 (115)
Z-axis travel	mm	640	640	1600	1600	820
X-axis travel	mm	290	290	290	290	320
Z-axis rapid traverse	M/min	20	20	18	18	18
X-axis rapid traverse	M/min	20	20	18	18	18
Tool system		-	BMT-65	-	BMT-65	-
Number of tools		10 (12)	12	10 (12)	12	10 (12)
Turning tool size	mm	25 x 25	25 x 25	25 x 25	25 x 25	32 x 32
Boring tool size	mm	40	40	40	40	50
Tailstock travel	mm	550	550	1510	1510	820
Quill travel	mm	130	130	130	130	120
Quill diameter	mm	90	90	90	90	110
Quill taper hole	MT	5	5	5	5	5
Quill drive		Hydraulic	Hydraulic	Hydraulic	Hydraulic	Hydraulic
Tailstock positioning		Manual	Manual	Manual	Manual	Programmable
Dimensions (LxWxH)	M	3.5 x 1.95 x 2	3.5 x 1.95 x 2	4.7 x 2 x 2	4.7 x 2 x 2	4.4 x 2.1 x 2.2
Machine weight	kg	5800	5800	9000	9000	8880

■ Specifications are subject to change without notice.

FBL-360MC	FBL-360L	FBL-360LMC	FBL-460	FBL-460MC	FBL-460L	FBL-460LMC
770	770	770	840	840	840	840
550	550	550	662	662	662	662
452	570	452	650	530	650	530
739	2026	1997	694	665	1974	1945
1020	2300	2300	820	820	2200	2200
A2-8 (A2-11)	A2-8 (A2-11)	A2-8 (A2-11)	A2-15	A2-15	A2-15	A2-15
12 (15)	12 (15)	12 (15)	15	15	15	15
105 (134)	105 (134)	105 (134)	160	160	160	160
2500 (1500)	2500 (1500)	2500 (1500)	1400	1400	1400	1400
18.5 / 22 (22 / 26)	22 / 26 (30 / 37)	18.5 / 22 (22 / 26)	22 / 26 (30 / 37)	22 / 26 (30 / 37)	22 / 26 (30 / 37)	22 / 26 (30 / 37)
91 (115)	91 (115)	91 (115)	140	140	140	140
820	2100	2100	820	820	2100	2000
320	320	320	360	360	360	360
18	18	18	18	18	18	18
18	18	18	18	18	18	18
BMT-75	-	BMT-75	-	BMT-75	-	BMT-75
12	10 (12)	12	10 (12)	12	10 (12)	12
32 x 32	32 x 32	32 x 32	32 x 32	32 x 32	32 x 32	32 x 32
50	50	50	50	50	50	50
820	2000	2000	820	820	2000	2000
120	120	120	120	120	120	120
110	110	110	110	110	110	110
5	5	5	5	5	5	5
Hydraulic	Hydraulic	Hydraulic	Hydraulic	Hydraulic	Hydraulic	Hydraulic
Programmable	Programmable	Programmable	Programmable	Programmable	Programmable	Programmable
4.4 x 2.1 x 2.2	5.8 x 2.25 x 2.3	5.8 x 2.25 x 2.3	4.3 x 2.25 x 2.2	4.3 x 2.25 x 2.2	5.8 x 2.25 x 2.3	5.8 x 2.25 x 2.3
8880	12760	12760	9500	9500	13500	13500



FOCUS CNC CO., LTD.

www.focuscnc.com.tw

No. 20-1, Alley 65, Lane 140, Dalin Road, Daya Dist., Taichung City 428, Taiwan

TEL: 886-4-2560-6067 FAX: 886-4-2567-7938 E-mail: focus@focuscnc.com.tw

Dimensions

Unit: mm

FBL-300 / MC

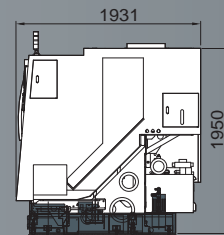
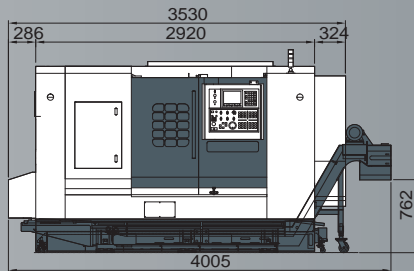

FBL-300L / MC

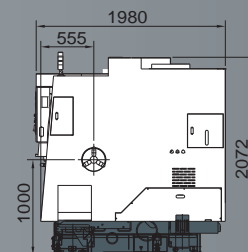
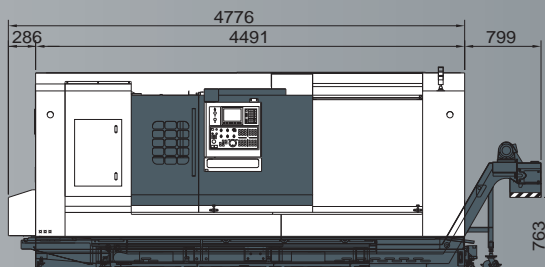

FBL-360 / 460 / MC

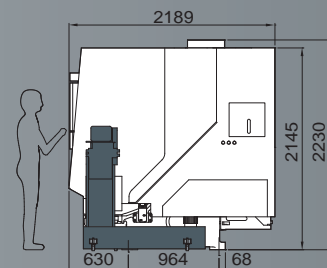
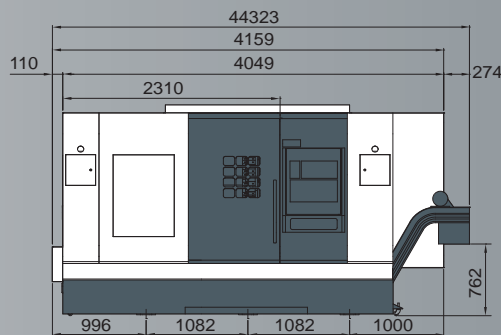

FBL-360L / 460L / MC

